

IT - ISTRUZIONI DI MONTAGGIO
EN - ASSEMBLY INSTRUCTIONS
DE - MONTAGEANLEITUNG
FR-INSTRUCTIONSDEMONTAGE

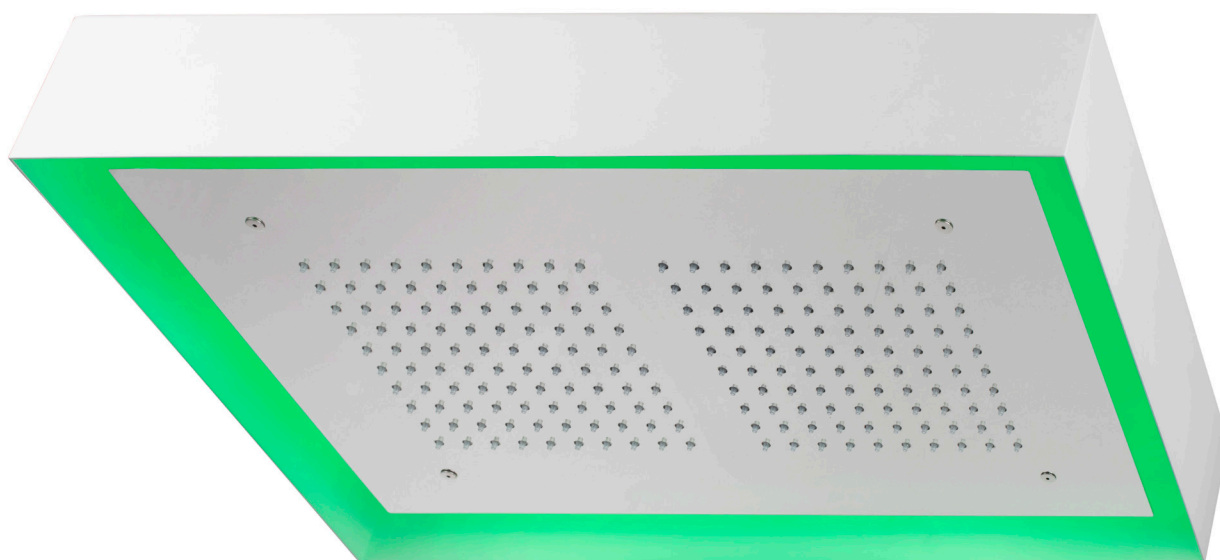

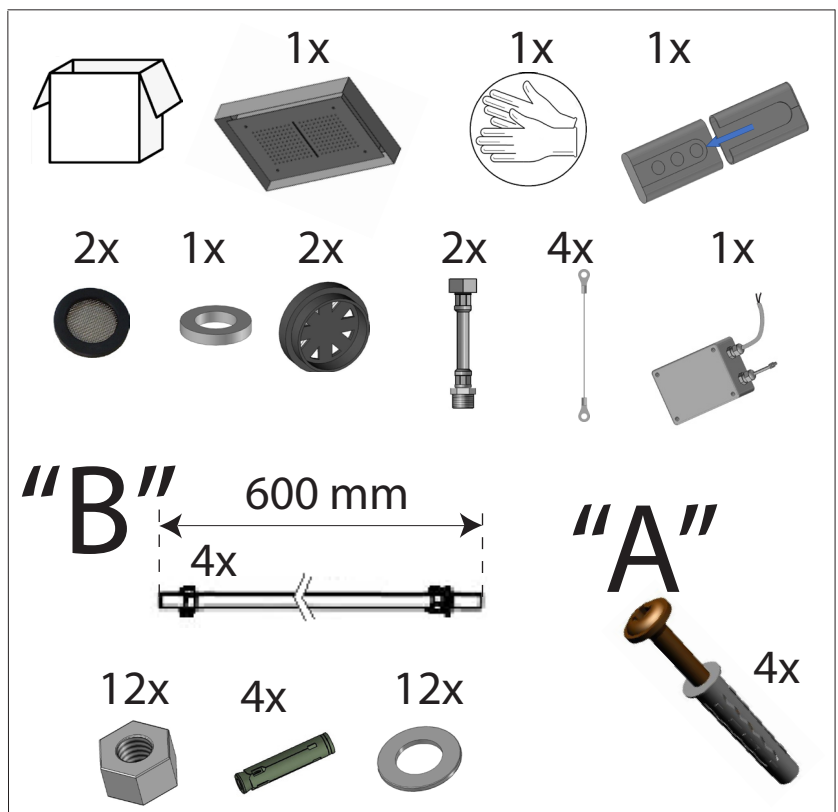

IT-L'apparechi deve essere installato da personale abilitato ai sensi per l'effetto delle leggi in vigore.
 EN - According to the law, all installation and maintenance operations require a qualified person.
 DE - Das Gerät muss von qualifiziertem Personal gemäß den geltenden Gesetzen installiert werden.
 FR-L'appareil doit être installé par du personnel qualifié conformément et pour l'effet des lois en vigueur.

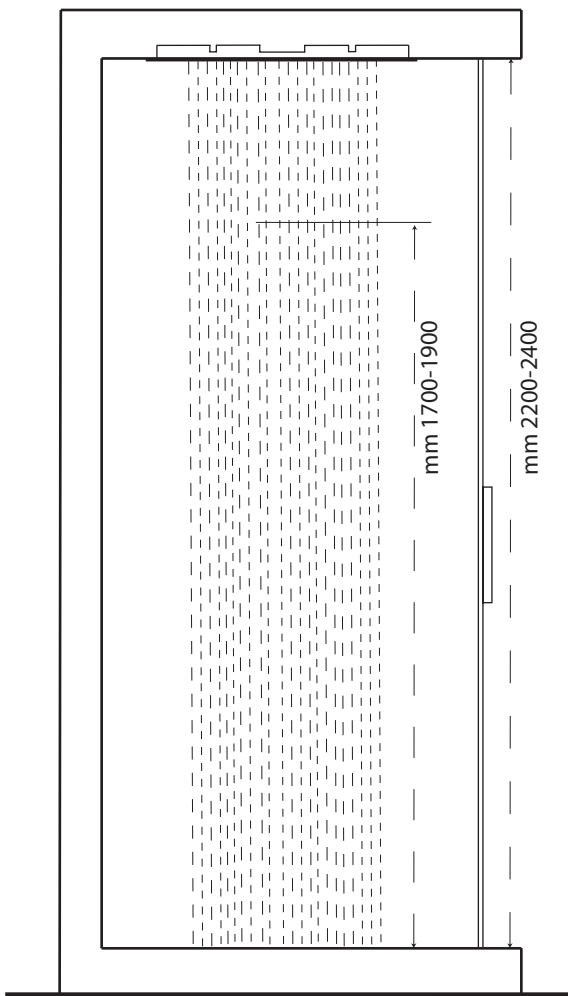
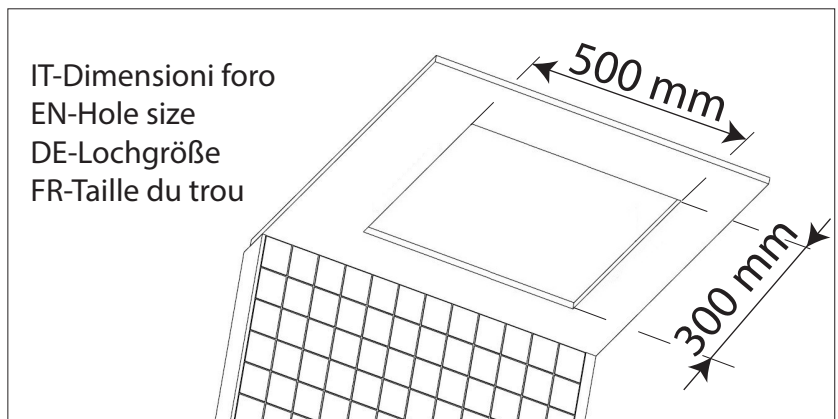
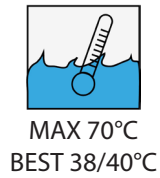
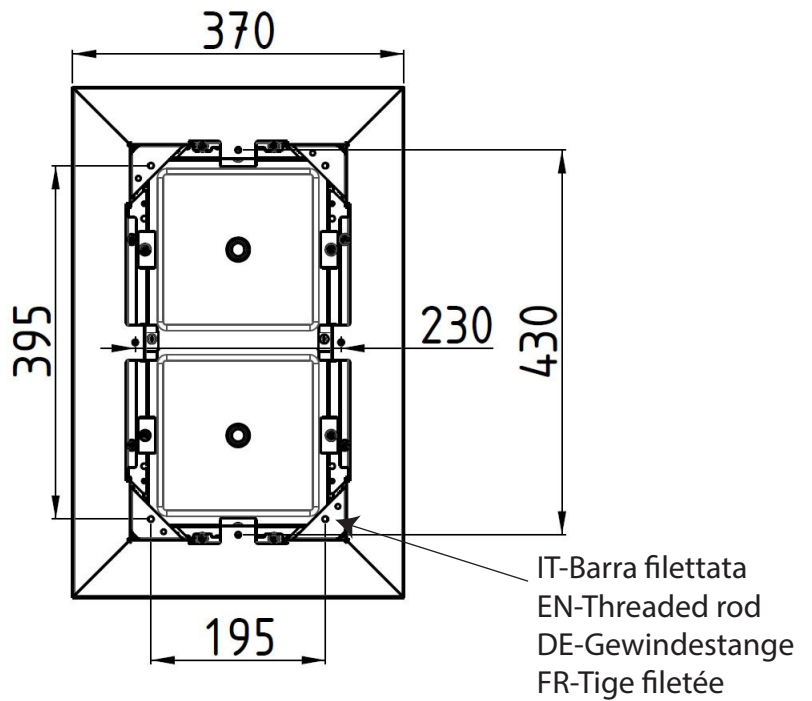
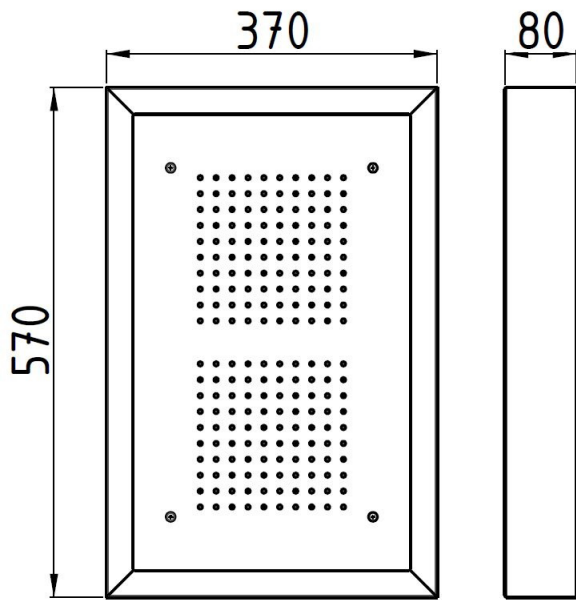
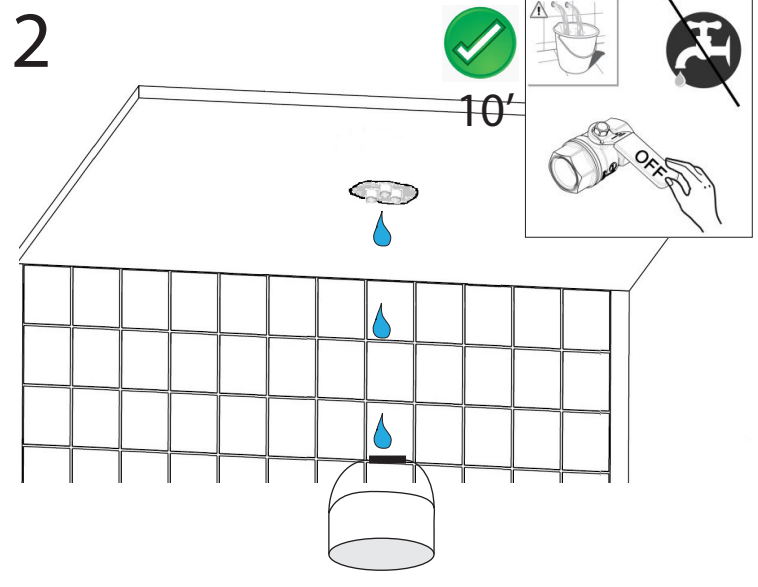
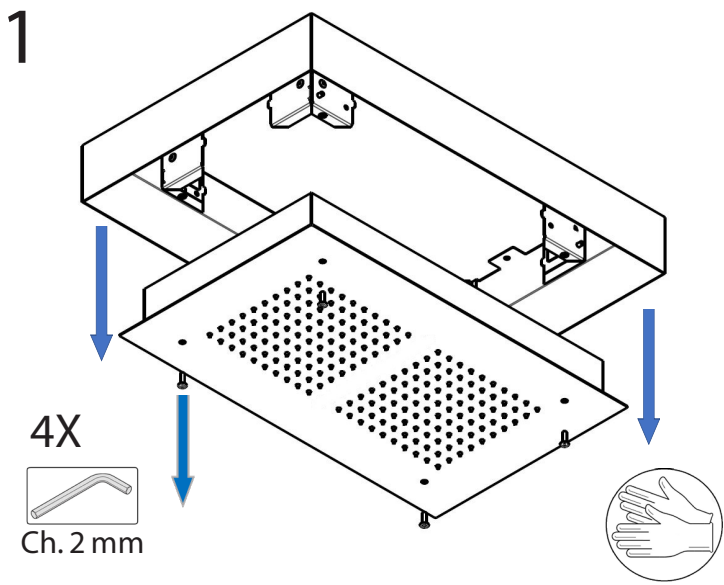

"3A"

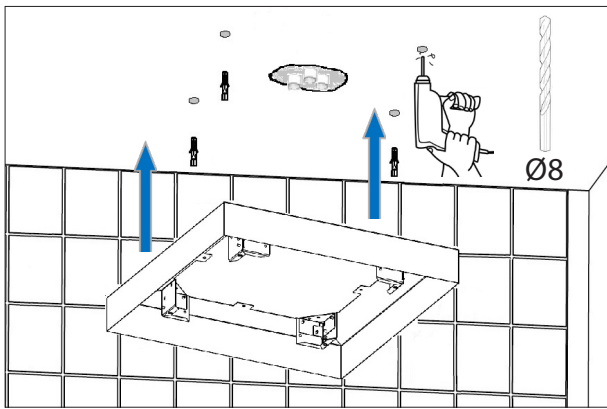
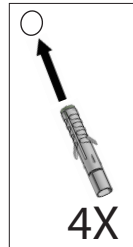
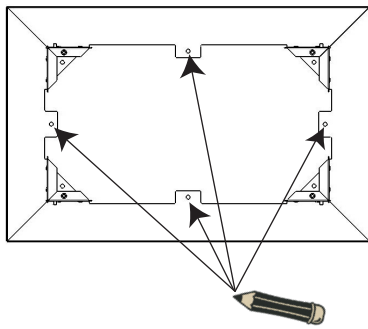

"3B"

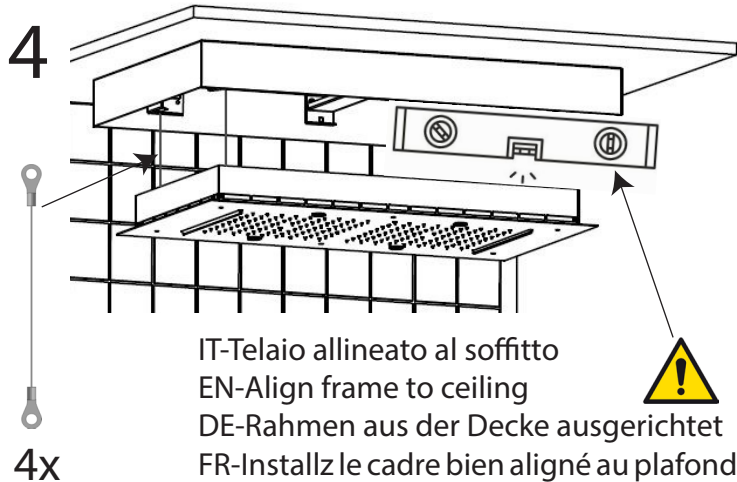
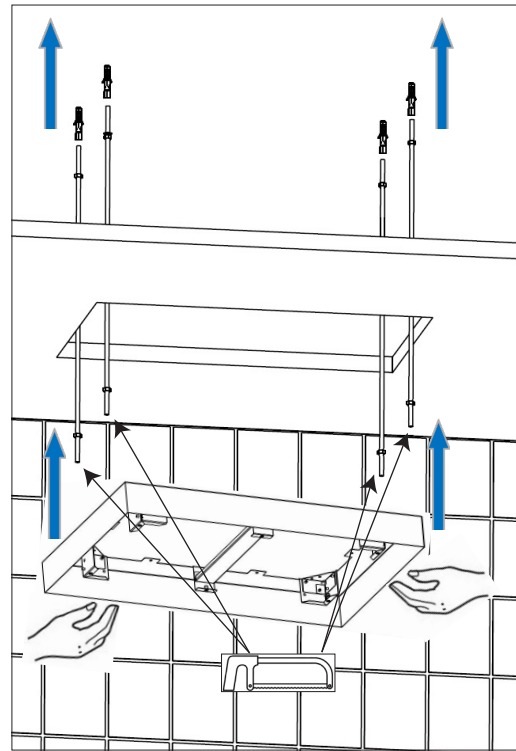
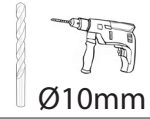

- ! IT-Cavo di sicurezza (se fornito)
EN-Safety cable (if supplied)
DE-Sicherheitskabel (sofern vorhanden)
FR-Câble de sécurité (si fourni)

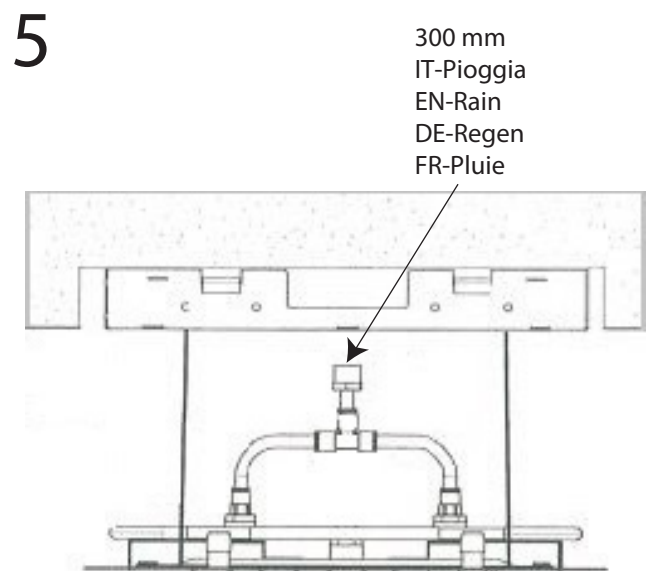

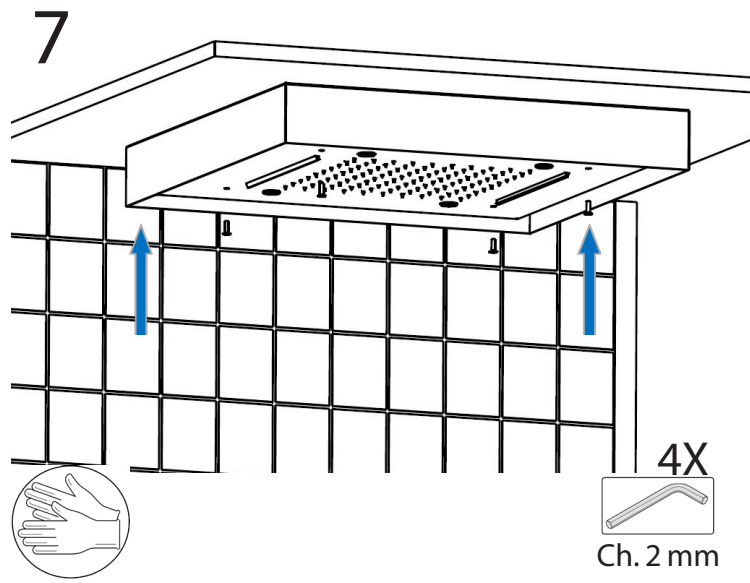
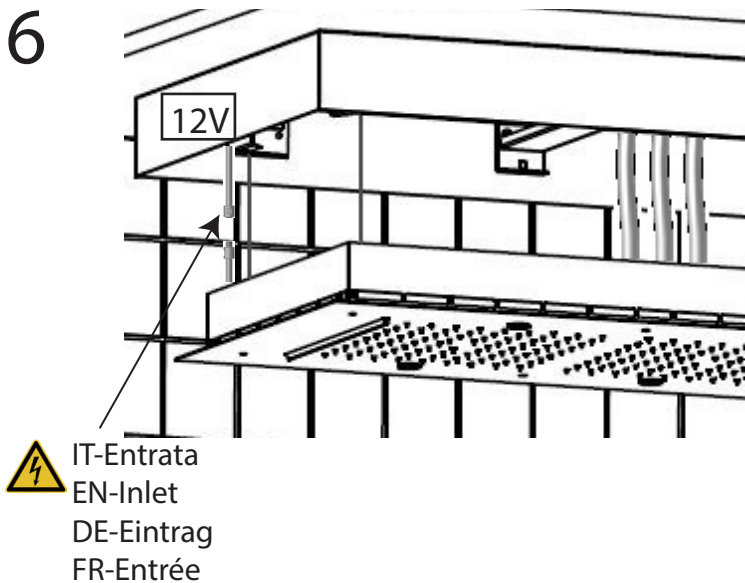

CROMOTERAPIA - CHROMOTHERAPY - FARB THERAPIE - CHROMOTHÉRAPIE

Telecomando Wireless / Wireless remote control / Funkfernbedienung / Télécommande sans fil

- ⚡ IT - Prima di qualsiasi operazione togliere sempre la tensione all'impianto.**
EN - Always turn voltage off before performing any operation on the electric system.
DE - Vor jedem Vorgang immer die Spannung der elektrischen Anlage entfernen.
FR - Coupez toujours la tension avant d'effectuer toute opération.

IT-Installare l'alimentatore Class 2-12Vac +/-3%-Min.35VA nella zona 3 conforme alle distanze di sicurezza previste dalle normative CEI.

EN- Install the Class 2 - 12 Vac +/- 3% - Min. 35 VA device in zone 3, as per the IEC regulations about safety distance.

DE- Installieren Sie das Netzteil der Klasse 2-12VDC +/-3%-Min.35VA in Zone 3 gemäß den Sicherheitsabständen, die in den CEI-Vorschriften vorgeschrieben sind.

FR- Installez l'appareil Classe 2-12Vca +/-3%-Min.35VA dans la zone 3 en respectant les réglementations CEI sur la distance de sécurité.

IT - Collegamento elettrico

EN- Electrical connection setup

DE- Aufbau der elektrischen Verbindung

FR- Configuration de la connexion électrique

IT-Tensione EN-Voltage DE-Stromspannung FR-Tension	Frequenza Frequency Frequenz La fréquence	Potenza nominale Max. Max. rated power input Max. spezifizierte Leistung Max. puissance d'entrée nominale	Grado di protezione parte elettrica Protection level of electrical parts Schutzgrad für elektrische Teile Niveau de protection des pièces électriques	Grado di protezione pulsante Button protection level Schutzgrad Knopf Niveau de protection des boutons
100-240 VAC	50-60 Hz	30 W	IP55	IP64

IT-Scatola di derivazione con alimentatore

EN-Junction box with power supply

DE-Verteilerkasten mit Netzteil

FR-Boîte récepteur avec alimentation

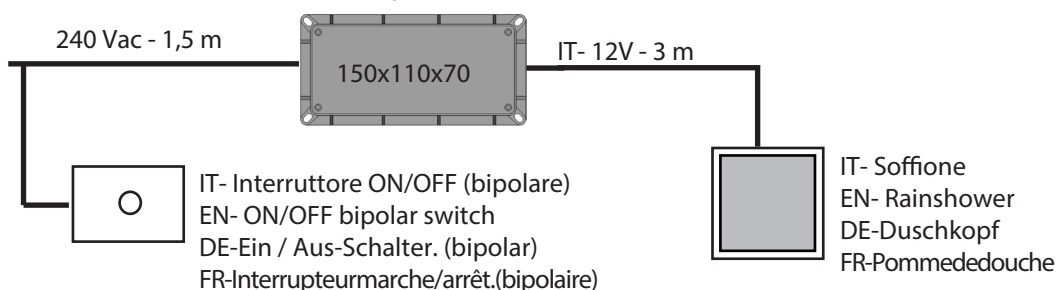

IT-Modalità di funzionamento LED RGB

EN-Mode of operation of the RGB LED

DE-Funktionsweise der RGB-LED

FR-Modedefonctionnementde la LED RGB

IT - Sequenza colori: Bianco - Rosso - Verde - Blu - Giallo - Fucsia - Azzurro.

EN-Color sequence: White - Red - Green - Blue - Yellow - Fuchsia - Bright Blue.

DE-Farbfolge: Weiß - Rot - Grün - Blau - Gelb - Fuchsia - Hellblau.

FR-Séquence de couleurs: blanc - rouge - vert - bleu - jaune - fuchsia - bleu vif.



IT- Cromoterapia modalità automatica, rotazione colori come sequenza ogni minuto.
EN- Automatic chromotherapy, color rotation every minute following the sequence above.
DE- Automatische Farbtherapie, Farbrotation als Sequenz jede Minute.
FR- Chromothérapie mode automatique, rotation des couleurs en séquence toutes les minutes.



IT- Scelta manuale del colore
EN- Manual color selection
DE- Manuelle Auswahl der Farbe
FR- Choix de couleur



IT- Tasto ON/OFF
EN- ON/OFF switch
DE- Ein-/ Aus-Schalter
FR- Allumer / éteindre

IT - Telecomando Cromoterapia - EN - Chromotherapy remote control

DE - Fernbedienung für Chromotherapie - FR - Télécommande pour la Chromothérapie

IT - PRIMA INSTALLAZIONE

Abbinamento telecomando:

1. Impianto spento
 2. Inserire le batterie formato AAA alcaline nel telecomando
 3. Alimentare la corrente dell'impianto e attendere 10 secondi
 4. Premere il tasto centrale del telecomando entro 30 secondi
 5. Abbinamento OK!
- Durante l'abbinamento wireless le luci del prodotto lampeggiano di rosso.
 - La procedura di abbinamento deve essere fatta una sola volta, tuttavia in caso di spegnimento o riaccensione il sistema non è operativo sulle luci nei primi 60 secondi.

N.B.: Non utilizzare batterie ricaricabili

EN - FIRST INSTALLATION

Remote Control pairing:

1. Turn the system off
 2. Insert the AAA size alkaline batteries into the remote control
 3. Power the system on and wait for 10 seconds
 4. Press the center on the remote control within 30 seconds
 5. Pairing accomplished!
- During the pairing process, the rain shower will briefly flash red.
 - The pairing procedure needs only be done once, however in the event of powering it off and then on again the system's light will not be operational during the first 60 seconds.

NB: Do not use rechargeable batteries

DE - ERSTE INSTALLATION

Fernbedienungspaarung:

1. Schalten Sie das System aus
 2. Legen Sie die Alkalibatterien der Größe AAA in die Fernbedienung ein
 3. Schalten Sie das System ein und warten Sie 10 Sekunden
 4. Drücken Sie innerhalb von 30 Sekunden die mittlere Taste auf der Fernbedienung.
 5. Paarung durchgeführt!
- Während des Pairing-Vorgangs blinkt der Regenschauer kurz rot.
 - Das Pairing-Verfahren muss nur einmal durchgeführt werden. Wenn das System aus- und wieder eingeschaltet wird, ist das Systemlicht während der ersten 60 Sekunden nicht betriebsbereit.

Hinweis: Verwenden Sie keine wiederaufladbaren Batterien

FR - PREMIÈRE INSTALLATION

Appariement de la télécommande à la douche pluie:

1. Éteignez le système, s'il vous plaît
 2. Insérez les piles alcalines AAA dans la télécommande
 3. Allumez le système et attendez 10 secondes
 4. Appuyez sur le bouton central de la télécommande dans les 30 secondes.
 5. Appariement accompli!
- Au cours de la procédure de couplage, la douche pluie clignotera brièvement en rouge.
 - La procédure de découplage doit être effectuée qu'une seule fois. Toutefois, si vous l'éteignez puis rallumez le système, le voyant ne sera pas opérationnel pendant les 60 premières secondes.

NB: Ne pas utiliser de piles rechargeables

IT- Predisposizione elettrica
 EN- Electrical setup
 DE- Elektrische Veranlagung
 FR- Installation électrique

IT- Soffione
 EN- Rainshower
 DE- Duschkopf
 FR- Pommededouche

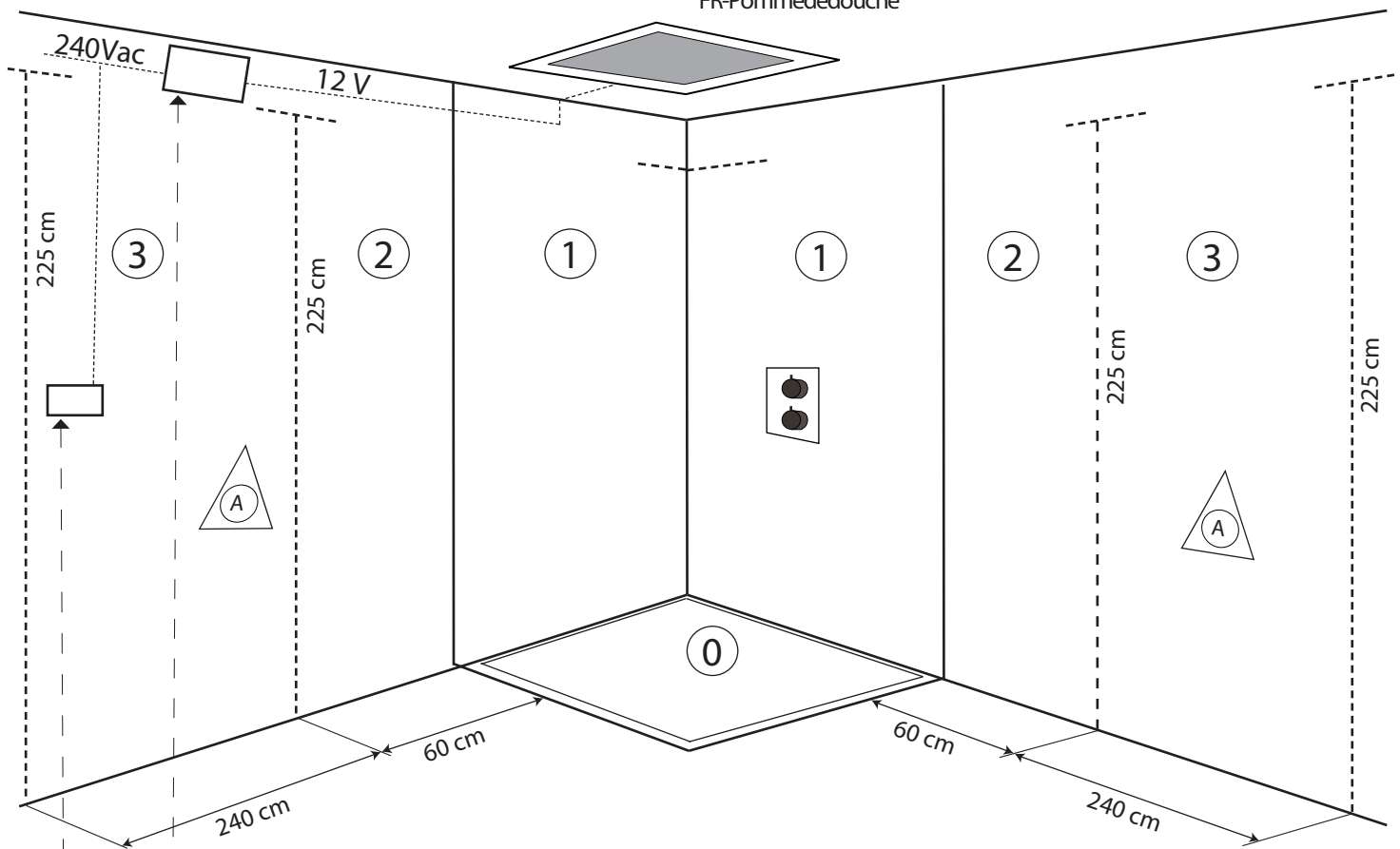

IT- SCATOLA DI DERIVAZIONE

Ipotetica posizione per scatola di derivazione (cavi di 1,5m 240Vac, esterna a cabina doccia).

EN- JUNCTION BOX

Ideal position of the in-wall junction box (cable: 1.5 m, 240Vac. outside the shower box).

DE- VERTEILERKASTEN

Bestmögliche Position für Verteilerkasten (1,5m 240 VAC Kabel, außerhalb der Duschkabine)

FR- BOÎTE RÉCEPTEUR

Position hypothétique de la boîte de jonction dans le mur (câbles de 1,5m, 240Vac. l'extérieur de la cabine de douche).



Norme CEI
 IEC regulations
 IEC-Normen

IT- Zona (3) d'installazione della scatola di derivazione.
 EN- Installation area (3) for the junction box.
 DE- Gebiet (3) der Installation des Verteilerkasten
 FR- Zone d'installation (3) de la boîte de jonction.

IT- Interruttore ON/OFF (bipolare), consigliato.
 EN- ON/OFF switch (bipolar), recommended.
 DE- EIN / AUS-Schalter (bipolar), empfohlen.
 FR- Interrupteur ON/OFF (bipolaire), recommandé.

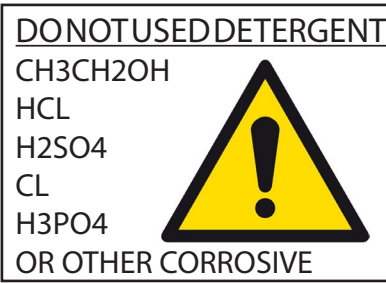

IT-LAGARANZIADELPRODOTTONONCOPRE

L'utilizzo improprio.
L'errata predisposizione dell'impianto idraulico.
Danni causati da depositi di calcare o altre impurità.
Detergenti non adatti.

EN - NOT COVERED BY PRODUCT CARE

Not correct use.
Incorrect setup of the hydraulic system.
Water impurities or limestone deposits.
Improper detergents.

DE - DIE PRODUKTGARANTIE GILT NICHT

Die falsche Verwendung
Die falsche Anordnung des Hydrauliksystems.
Schäden durch Kalkablagerungen oder andere Verunreinigungen.
Ungeeignete Reiniger.

FR-LAGARANTIEDUPRODUITNECOUVREPAS

Utilisation incorrecte.
La mauvaise disposition du système hydraulique.
Dommages causés par des dépôts de calcaire ou d'autres impuretés.
Nettoyants inappropriés.



IT - DUE ANNI DIGARANZIA DEL PRODOTTO

Contro i difetti o vizi di fabbricazione.

EN - TWO-YEAR PRODUCT CARE

Against defects of fabrication.

DE - ZWEIJAHRELANGPRODUKTGARANTIE

Gegen Mängel oder Herstellungsfehler

FR-GARANTIEDEPRODUITSDEDEUXANSO

Contre les défauts de fabrication.

IT-ATTENZIONE:Sideclinaogniresponsabilitàrelativaadeventualiinesattezzecontenuteinquesteistruzioni dovute ad errori di trascrizione.

EN-WARNING:Wedeclineallresponsibilityforeventualinaccuracycontainedintheinstructionsdueto transcript errors.

DE-ACHTUNG:WirlehnenjedeVerantwortungfürUngenauigkeitenindiesenAnleitungaufgrundvon Transkriptionsfehlern ab.

FR-ATTENTION:Nousdéclinonstouteresponsabilitépourtouteinexactitudecontenuedanscesinstructions en raison d'erreurs de transcription.

